

**A High Performance loudspeaker
featuring the SEAS Prestige FEA18RCZ fullrange driver
Designed at the SEAS R&D laboratory.**

The FEA18RCZ is an 18cm full range driver offering excellent efficiency and extended bandwidth in a compact package. Driven by low to medium power, high quality amplifiers from good signal sources, this driver is capable of providing high quality sound reproduction. This kit offers the listener a loudspeaker system with a precise, coherent and engaging listening experience using this high quality driver.

Enclosure

We propose to use a ported cabinet of approximately 19 litres internal volume. With no damping material inside the resulting tuning frequency should be 47 Hz, along with an alignment that gives a slight bass boost around 90 Hz. It is recommend to half fill the cabinet with damping material, positioning the damping material away from the rear of the driver and port. Glass fibre material is well suited for damping, but precautions should be taken to avoid health risks. Dacron wadding is a good alternative, and much more pleasant to work with.

Rear horn loading cabinets are often used with drivers of this type. We encourage interested clients to experiment with such constructions and to share their experience. Care should be taken when using the driver in ported or rear horn loaded cabinets to avoid mechanical overload due to excessive cone excursions at low frequencies.

It is recommended to make the cabinet from high quality materials of adequate thickness. The cabinet sides should be cut precisely, so that they can be accurately joined together. Internal bracing and damping of structural resonances of the cabinet walls is advised. In the drawings below one horizontal brace has been used inside the cabinet to improve the rigidity of the cabinet, but more bracing can be added if deemed necessary. The ends of the port should be chamfered to reduce air noise.

Good quality cables and connectors should be used throughout. It is best to solder the cable connections inside the cabinet to the driver for a secure assembly.

Listening room and placement

Good quality stands should be used to bring the centre of the driver to the listener's ear level. Depending on the size and performance of the listening room, it is important to find positions where the loudspeakers will perform at their best. Placing the cabinets close to the walls or corners will result in more powerful bass, but may also bring about response irregularities in the bass/midrange area. Some experimentation is recom-

mended in order to find cabinet positions which result in a good tonal balance.

The proposed loudspeaker system in this document has been designed to be used with the driver axes pointing towards the listening position in a classical stereophonic setup. However, if the high frequency level is perceived to be too loud the cabinets can be turned so that the driver axes cross in front of the listening position (toe-in). This may result in the desired tonal balance by attenuating the high frequency response above 3 kHz.

Response adjustment

It is desirable to attenuate the high frequency output from the driver. This may be done by simply putting a parallel connection of an inductor and a resistor in series with the driver.

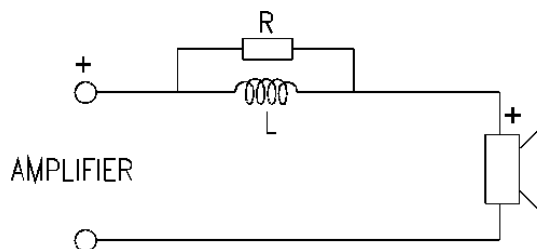

Below you can see the effect of the recommended network on the axial sound pressure frequency response measured in the proposed 19 litre ported enclosure. Black: No network. Red: Inductor $L = 1.2\text{mH}$, resistor $R = 18\text{ Ohms}$.

The parallel resistor controls the high frequency attenuation level. A larger resistance results in more attenuation. The inductor controls the frequency range which is attenuated. Clients can use other component values to adjust the loudspeaker frequency response to their preferred preference. Metal film resistors of at least 10 Watts are recommended. The system is designed to be used with an air core inductor; ferromagnetic core inductors should not be used. Inductors should be wound from a heavy conductor for a low series resistance, preferably less than 0.4 Ohms.

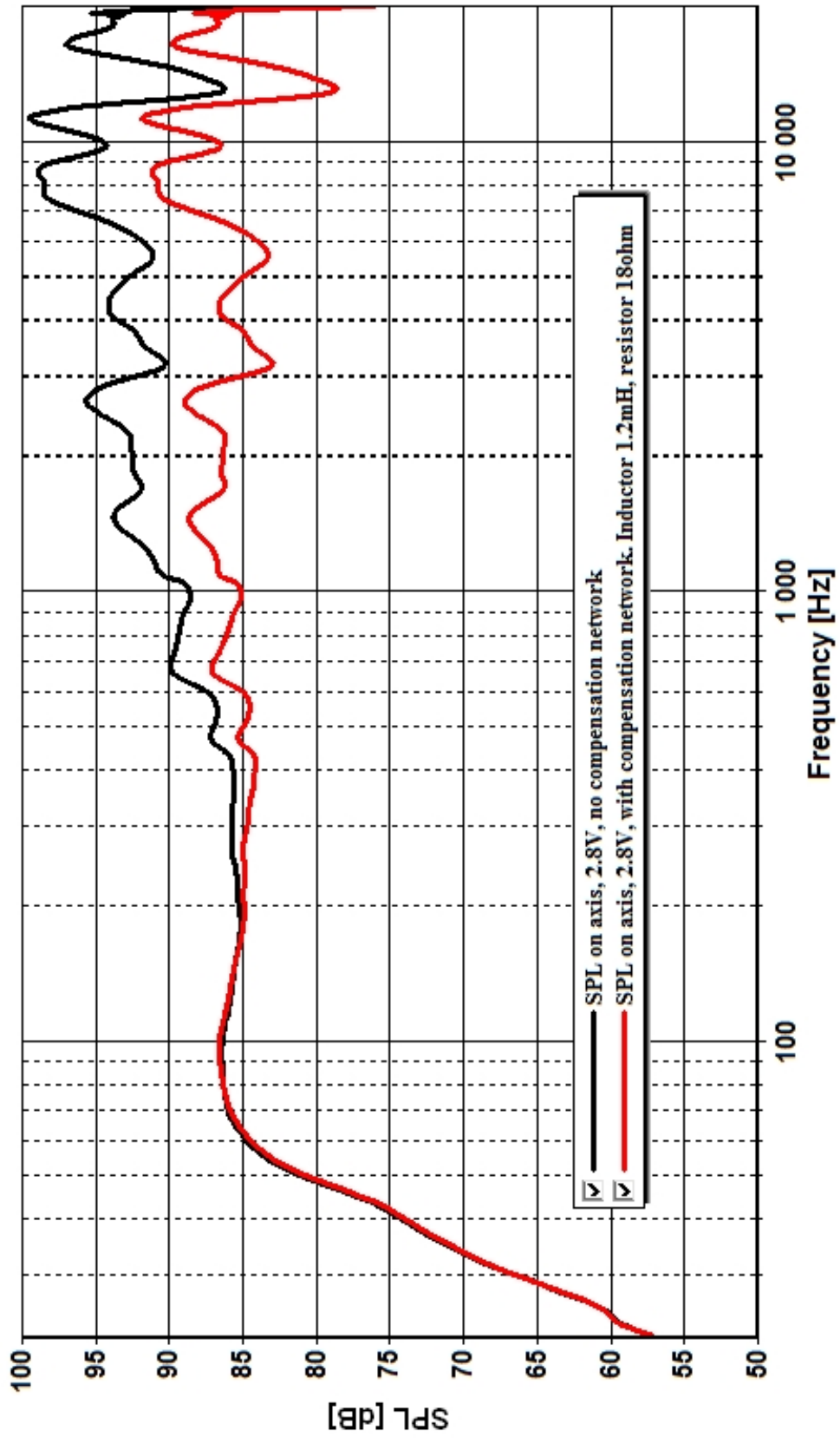

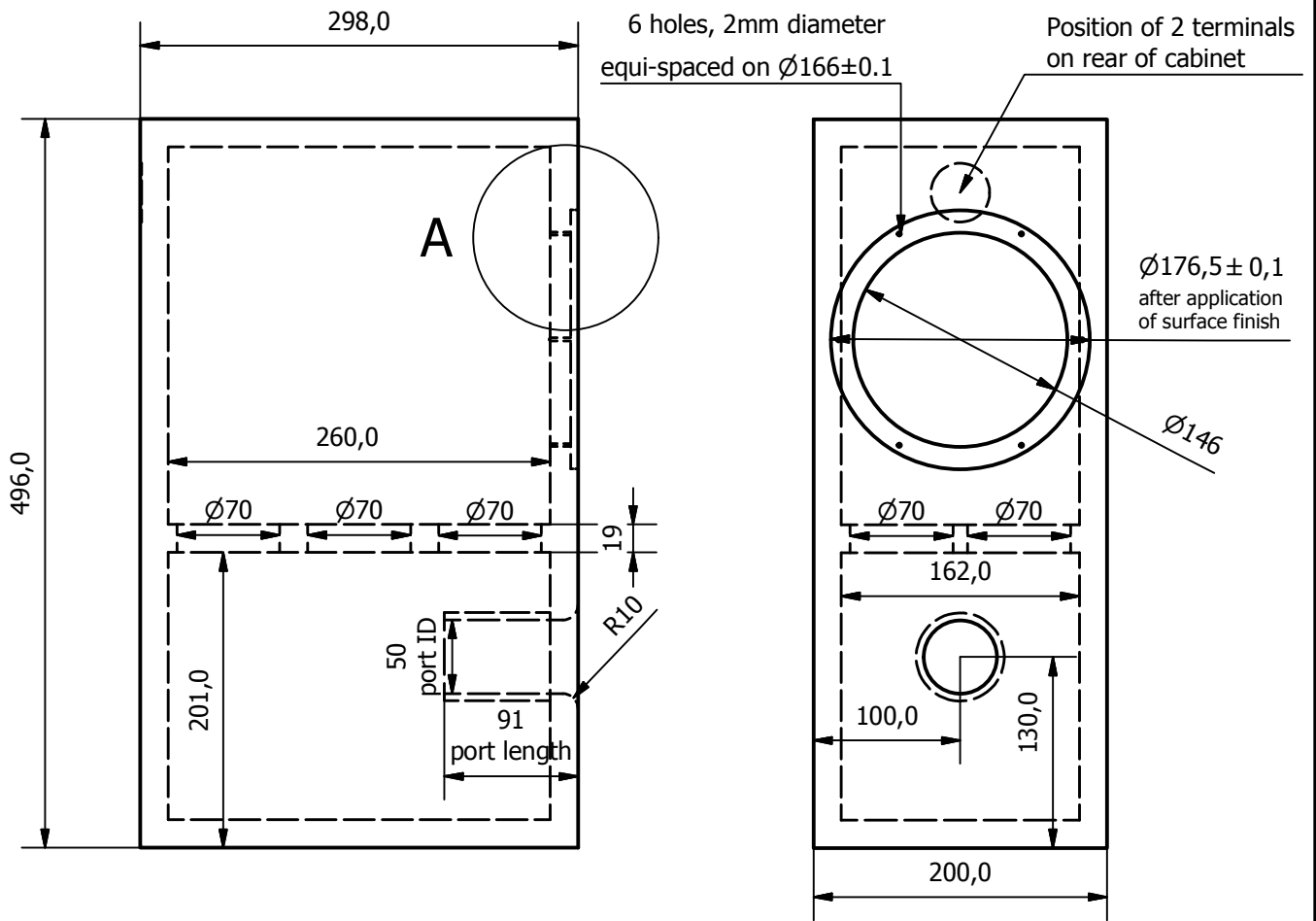

Material: 19mm wood
All dimensions in millimeters

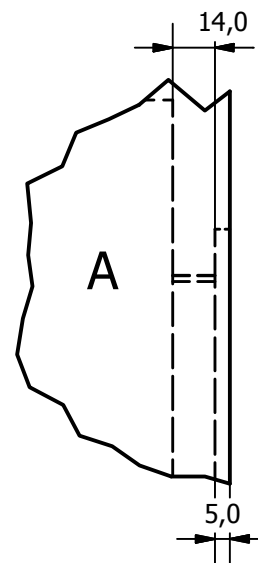
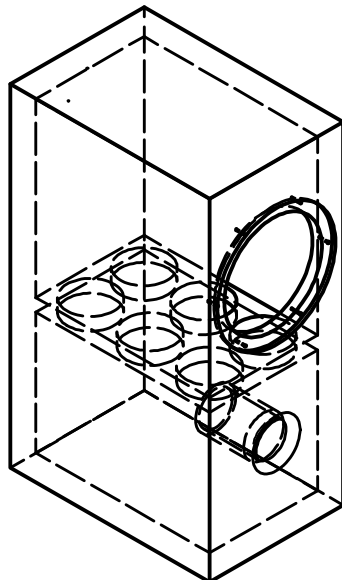

This drawing is SEAS property.
Every duplicating, utilization
or conveyance to a third party
is punishable - according to law.

Designed by Julien / Peter	Checked by	Approved by	Date	Date 24/02/2017
		Cabinet FEA18RCZ application note		
		Edition 2	Scale	