

Classical handcoated paper cone and matching natural rubber surround produce a well behaved roll off characteristic and reduce potential resonance problems.

Long, high temperature voice coil wound on an aluminium voice coil former gives low distortion and high power handling capacity.

Large magnet system provides high efficiency and good transient response.

Bumped backplate in the magnet system allows maximum utilization of the long voice coil without mechanical limitation.

Extremely stiff and stable injection moulded metal basket keeps the critical components in perfect alignment. Large windows in the basket both above and below the spider reduce sound reflexion, air flow noise and cavity resonance to a minimum.

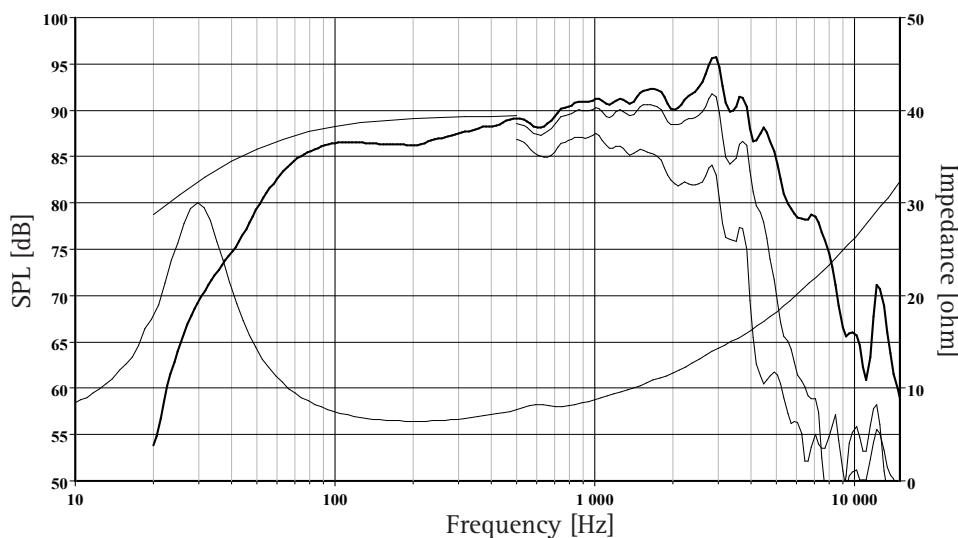

The frequency responses above show measured free field sound pressure in 0, 30, and 60 degrees angle using a 21L closed box. Input 2.83 V_{RMS}, microphone distance 0.5m, normalized to SPL 1m. The dotted line is a calculated response in infinite baffle based on the parameters given for this specific driver. The impedance is measured in free air without baffle using a 2V sine signal.

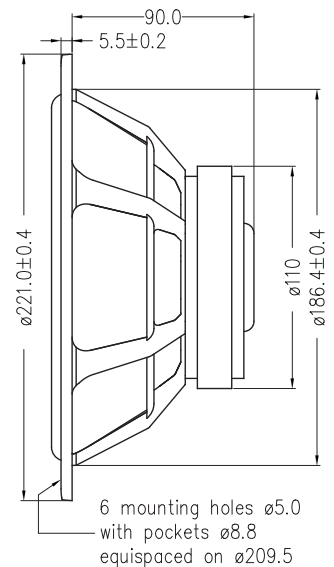

Nominal Impedance	8 Ohms	Voice Coil Resistance	6.1 Ohms
Recommended Frequency Range	30 - 3000 Hz	Voice Coil Inductance	1.0 mH
Short Term Power Handling *	250 W	Force Factor	7.0 N/A
Long Term Power Handling *	80 W	Free Air Resonance	29 Hz
Characteristic Sensitivity (2,83V, 1m)	89.5 dB	Moving Mass	20.9 g
Voice Coil Diameter	39 mm	Air Load Mass In IEC Baffle	2.02 g
Voice Coil Height	18 mm	Suspension Compliance	1.4 mm/N
Air Gap Height	6 mm	Suspension Mechanical Resistance	2.05 Ns/m
Linear Coil Travel (p-p)	12 mm	Effective Piston Area	230 cm ²
Maximum Coil Travel (p-p)	26 mm	VAS	97 Litres
Magnetic Gap Flux Density	1.0 T	QMS	2.04
Magnet Weight	0.64 kg	QES	0.52
Total Weight	2.20 kg	QTS	0.41